



ATTENTION!

If any components of this unit are broken, do not operate properly, or for product returns, please contact Weston Products LLC
Phone: 1-800-814-4895 (Outside the U.S. 440-638-3131)
20365 Progress Drive, Strongsville, Ohio 44149
WestonProducts.com

All Trademarks and Registered Trademarks are property of the respective companies.

SAVE THESE INSTRUCTIONS!

Refer to them often and use them to instruct others.



**STAINLESS STEEL
MANDOLINE
VEGETABLE
SLICER**

MODEL #01-0006



Due to constant factory improvements, the product pictured might differ slightly from the product received.

REV040711

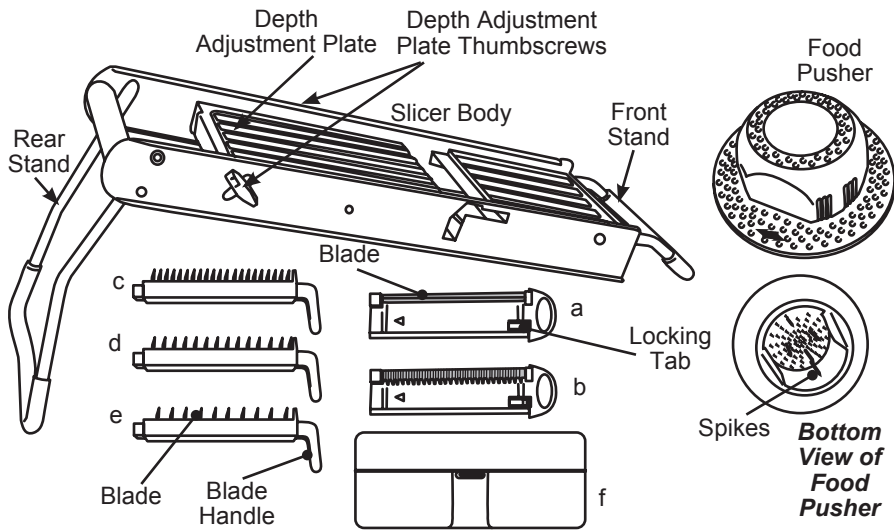

WESTON WARRANTY INFORMATION

SAVE THIS WARRANTY INFORMATION FOR YOUR RECORDS!

Weston Products LLC warrants to the ORIGINAL RETAIL PURCHASER of this product that if operated in accordance with the printed instruction accompanying it, then for a period of 1 year from the date of purchase, the product shall be free from defects in material and workmanship.

The Warranty Card, along with a copy of the original receipt, must be received by Weston Products LLC within 30 days from purchase date for the warranty to apply. Failure to send the completely filled out Warranty Card, along with a copy of the original receipt, will void the warranty.

The product must be delivered to or shipped freight prepaid to Weston Products LLC for warranty services, in either its original packaging or similar packaging affording an equal degree of protection. Damage due to shipping is not the responsibility of the company. Weston Products LLC charges a \$35.00 per hour bench charge. **NOTE:** No repairs will be started without the authorization of the customer. The return shipping cost to the customer will be added to the repair invoice.

Weston Products LLC will repair (or at its discretion, replace) the product free of charge, if in the judgment of the company, it has been proven to be defective as to seller's labor and material, within the warranty period.

New or rebuilt replacements for factory defective parts will be supplied for one (1) year from the date of purchase. Replacement parts are warranted for the remainder of the original warranty period.

For non-warranty repairs, contact Weston Products LLC's Customer Service at 1-800-814-4895 M-F 8am-5pm EST (outside of the United States 440-638-3131) to obtain a Return Merchandise Authorization Number (RMA Number). Weston Products LLC will refuse all returns that do not contain this number. **DO NOT RETURN THE UNIT WITHOUT PROPER AUTHORIZATION FROM WESTON PRODUCTS LLC.**

LIMITATIONS: The warranty is void if the product is used for any purpose other than that for which it is designed. The product must not have been previously altered, repaired, or serviced by anyone else other than Weston Products LLC. If applicable, the serial number must not have been altered or removed. The product must not have been subjected to accident in transit or while in the customer's possession, misused, abused, or operated contrary to the instructions contained in the instruction manual. This includes failure caused by neglect of reasonable and necessary maintenance, improper line voltage and acts of nature. This warranty is not transferable and applies only to U.S. and Canadian sales.

Except to the extent prohibited by applicable law, no other warranties whether expressed or implied, including warranty merchantability and fitness for a particular purpose, shall apply to this product. Under no circumstances shall Weston Products LLC be liable for consequential damages sustained in connection with said product and Weston Products LLC neither assumes nor authorizes any representative or other person to assume for it any obligation or liability other than such as is expressly set forth herein. Any applicable implied warranties are also limited to the one (1) year period of the limited warranty.

This warranty covers only the product and its specific parts, not the food or other products processed in it.

CUT ALONG THE DOTTED LINE AND SEND THE WARRANTY CARD ALONG WITH A COPY OF YOUR ORIGINAL PURCHASE RECEIPT TO:

Weston Products LLC
20365 Progress Drive, Strongsville, OH 44149

COMPONENT LIST

DIAGRAM NUMBER	PART DESCRIPTION	PART NUMBER
a	Slicing Blade	01-0007
b	Waffle Blade	N/A
c	3/16" (5 mm) Julienne Blade	N/A
d	5/16" (7 mm) Julienne Blade	N/A
e	7/16" (10 mm) Julienne Blade	N/A
f	Blade Case	N/A

If any components of this unit are broken or the unit does not operate properly, call Weston Products LLC Toll Free at

1-800-814-4895

Monday thru Friday 8:00am-5:00pm EST. Outside the U.S. call 440-638-3131

WESTON WARRANTY CARD

SEND THIS CARD ALONG WITH A COPY OF YOUR ORIGINAL PURCHASE RECEIPT TO:
 WESTON WARRANTY, WESTON PRODUCTS LLC, 20365 PROGRESS DRIVE, STRONGSVILLE, OH 44149

Customer Name: _____

Address: _____

City/State/Zip: _____

Telephone Number: (_____) _____

E-Mail Address: _____

Original Date of Purchase: ____/____/____

Product Model #: _____

Serial # (if applicable): _____



To adjust thickness, loosen the **Depth Adjustment Plate Thumb Screws** on both sides of the **Slicer Body** and slide the **Depth Adjustment Plate** to the desired slicing thickness, then secure into place by tightening the **Depth Adjustment Plate Thumb Screws**.

7. Maintain constant pressure on the **Food Pusher** so that the **Spikes** continue to hold the vegetable/fruit.

TYPES OF SLICES

Julienne Blades

The three **Julienne Blades** that come with the **Vegetable Slicer** have the following thicknesses – 3/16", 5/16", and 7/16". The more teeth on the **Blade**, the THINNER the sticks of vegetable/fruit will be. The less teeth on the **Blade**, the THICKER the sticks of vegetable/fruit will be.

Only use the **Julienne Blades** with the **Straight Edge Slicing Blade**. Do not use them with the **Waffle Blade**.

- Cut the vegetables/fruit in sections corresponding to the desired length of the julienne strips (approximately 3"-6" (7.6 - 15.2 cm) long).
- Place the vegetable/fruit lengthwise onto the **Food Pusher Spikes**.

Smooth Blade

This is the **Vegetable Slicer's** main **Blade** and features a straight edge for basic slicing.

The straight edge of the **Smooth Blade** is ideal for slicing a variety of foods from carrots and cabbage to lemons and potatoes.

- For straight cuts, place the vegetable/fruit either endwise or lengthwise onto the **Food Pusher Spikes**.

Waffle Blade

The **Waffle Blade** creates crinkle and waffle cuts, and is easy to use with any fruit/vegetable. A crinkle cut requires only one pass over the **Blade**.

Waffle Cuts: For a waffle cut, the key is to adjust the height of the **Depth Adjustment Plate** so that the slices are only slightly thicker than the serrated edge of the **Blade**.

- Once you adjust the thickness of the **Depth Adjustment Plate**, place the food onto the **Food Pusher Spikes** and make a pass over the **Blade**.
- Next, rotate the vegetable/fruit 90° and make a second pass over the **Blade** to complete the cut. This rotation will create an opposing crinkle cut on each side of the vegetable/fruit.



GENERAL SAFETY RULES



READ AND FULLY UNDERSTAND ALL INSTRUCTIONS AND WARNINGS PRIOR TO USING THIS UNIT. YOUR SAFETY IS MOST IMPORTANT! FAILURE TO COMPLY WITH PROCEDURES AND SAFE GUARDS MAY RESULT IN SERIOUS INJURY OR PROPERTY DAMAGE. REMEMBER: YOUR PERSONAL SAFETY IS YOUR RESPONSIBILITY!

1. **KEEP FINGERS CLEAR** of the **Blade** at all times. **NEVER** push the product with your hands in line of the **Blade** when slicing. **ALWAYS** use the **Food Pusher**.
2. **NEVER** use fingers to scrape food away from the **Blade**. **SEVERE INJURY MAY RESULT**.
3. **NEVER LEAVE THE MANDOLINE SLICER UNATTENDED**. Close supervision is necessary when used near children. The **Mandoline Slicer** is **NOT** to be used by children.
4. **CHECK FOR DAMAGED PARTS**. Before using the **Slicer**, check that all parts are operating properly and perform the intended functions.
5. The manufacturer declines any responsibility in the case of improper use of this unit.
6. **NEVER** use any accessories or parts from other manufacturers. Doing so will **VOID YOUR WARRANTY** and may cause injury.
7. Be sure the **Mandoline Slicer** is stable during use. Both **Front** and **Rear Stands** should be securely on the work surface.
8. **DO NOT** use this **Mandoline Slicer** for frozen foods or anything other than food stuffs.
9. Remove the **Blade** after each use to clean. Clean with hot soapy water. Dry thoroughly. Protective/cut-resistant Kevlar Gloves are recommended whenever handling the **Blades**.
10. **DO NOT** use the **Mandoline Slicer** while under the influence of drugs or alcohol.

SAVE THESE INSTRUCTIONS!

Refer to them often and use them to instruct others.

ADDITIONAL ACCESSORIES AVAILABLE

Sauce Maker & Food Strainer	07-0801
Traditional Style Pasta Machine	01-0201
Non-Stick Hamburger Press	07-0301
Food Grade Silicone Spray	03-0101-W

These products and many more products can be ordered by visiting **WestonProducts.com** or by calling Weston Products LLC Toll Free at 1-800-814-4895 Monday thru Friday 8:00am-5:00pm EST. Outside the U.S. call 440-638-3131

CLEANING & DISASSEMBLY

Cleaning your **Mandoline Slicer** should be done immediately after use to prevent food from drying on the parts. The **Slicer Body** should be washed by hand in warm soapy water, rinsed, then dried immediately. Lightly oil the **Slicer Body** with a food safe lubricant before storing.

The **Blades** and the **Hand Guard/Food Pusher** can be washed in the top rack of a dishwasher. Carefully position these pieces where they won't cut or damage other utensils.

CAUTION: If hand washing the **Blades** and underside of **Hand Guard/Food Pusher**, always wipe AWAY from **Blade** edges. These surfaces are extremely sharp and can cause severe injury!

1. When finished slicing, remove any remaining material from the **Hand Guard/Food Pusher**.
2. Remove the **Slicing Blade** by holding on to the **Handle** and depressing the **Locking Tab**. Be careful during **Blade** removal as the **Blade** is sharp! Remember to always hold **Blade** by the handle.
3. If using a **Julienne Blade** in addition to the **Slicer Blade**, remove the **Julienne Blade** by holding on to the handle and carefully sliding it out of the **Slicer Body**.

CAUTION: Once **Blades** are removed, DO NOT immerse them in water! **Blades** should be washed either in a top rack of the dishwasher or by holding onto the **Blade** handle. With a soapy towel, wipe AWAY from the **Blade** edges. To rinse **Blade**, hold by the **Handle** and wipe with a clean, damp towel, or hold under running water. After **Blades** are clean and dry, BE SURE TO STORE OUT OF REACH OF CHILDREN!

4. Completely remove the **Depth Adjustment Plate Thumb Screws**. Once the **Thumb Screws** are removed, the **Depth Adjustment Plate** should slide out of the bottom of the **Slicer Body**.

5. If desired, the **Front** and **Rear Stands** can also be removed by simply squeezing the ends of the **Stand** together and removing from mounting holes. However, it is not typically necessary for proper cleaning.

ASSEMBLY INSTRUCTIONS

It is recommended that the Vegetable Slicer be thoroughly washed prior to use!

1. Using a flat and sturdy work platform, unfold the **Front** and **Rear Stands** of the **Slicer Body**. Position the **Vegetable Slicer** with the **Rear Stand** closest to you.
2. To insert your **Blade** of choice, carefully remove the **Blade** from holder, holding it by the **Blade Handle**. The arrow should be pointing to the right of the



Locking Tab facing up. Slide it into the right-hand side of the **Slicer Body** pushing it all the way in until it latches into place.



CAUTION: The **Blades** are very sharp! **NEVER** touch the **Blade**, always use the **Blade Handles**!

3. If using a **Julienne Blade** in conjunction with the **Straight Edge Slicing Blade**, install the **Straight Edge Slicing Blade** first, then install the **Julienne Blade** by holding it by the **Blade Handle**. Firmly slide it into right hand side of the **Slicer Body** pushing it all the way in until in place. **NOTE:** Only use **Julienne Blades** with the **Straight Edge Slicing Blade**. Do not use them with the **Waffle Blade**.

4. Once **Blade(s)** are installed, loosen the **Depth Adjustment Plate Thumb Screws** on both sides of the **Slicer Body** and slide the **Depth Adjustment Plate** to the desired slicing thickness, then secure into place by tightening the **Depth Adjustment Plate Thumb Screws**.



CAUTION: When moving **Depth Adjustment Plate**, hold **Depth Adjustment Plate** by the end farthest away from the **Blades** to avoid injury.

DIRECTIONS FOR USE

1. Install the **Blade(s)** according to the type of slicing you plan on doing.



CAUTION: The **Blades** are very sharp! **NEVER** touch the **Blade**, always use the **Blade Handles**!

2. Position the **Vegetable Slicer** on a steady, flat working surface, with the **Rear Stand** is closest to you.

3. **ALWAYS** use the **Food Pusher**. **NEVER** use your fingers, hands or other objects to push the food on the **Slicer**! The **Food Pusher** is designed so that it will not touch the **Blades** as you slide it up and down the face of the **Slicer**.

There are two arrows on the **Food Pusher**. Always make sure that these arrows are pointing down the face of the **Slicer**, toward the **Blades**. The elongated edges help keep it aligned on **Slicer**.

4. Cut vegetable/fruit to fit the width of the **Food Pusher**, 3-7/8" (9.8 cm) wide is the maximum. Trim tips and stems for uniformity.

5. Press the vegetable/fruit onto the **Food Pusher** so that the **Spikes** pierce into the vegetable/fruit.

6. To make slices, hold the knob on top of the **Food Pusher** and slide it DOWN the **Vegetable Slicer** and over the **Slicing Blade(s)**. **REMEMBER** to always slice away from yourself! Use smooth, steady strokes to cut the vegetables/fruits. Never attempt to cut too quickly.

NOTE: Several test cuts may be needed to achieve the desired cutting thickness.